



OHAUS BW

Washdown Compact Bench Scale



Dual display "T" models have a second display on the rear of the scale



The OHAUS BW Compact Bench Scale – Dependability, Durability, OHAUS Quality and Value

The OHAUS BW Series Compact Bench Scale is a cost-effective portioning, packing and general weighing scale designed to provide fast and accurate weighing performance in dry and washdown environments. With an internal sealed rechargeable lead-acid battery, NEMA 4 / IP65 housing and a high-speed display, the OHAUS BW Series offers durability and dependability in an affordable design.

Standard Features Include:

- Selectable lb, oz or g units
- Super fast weighing results within two seconds
- AC Adapter and 50-hour rechargeable battery (included)
- NEMA 4 / IP65 washdown protection for easy cleaning
- Over /under checkweighing feature with configurable LED and audible alarm
- Removable stainless steel platter
- Four level display brightness adjustment
- Battery power saving mode
- Single display or dual display "T" models available
- Legal for Trade: NTEP certified (lb, kg, g) and Measurement Canada approved (g, lb, oz)

BW Series Washdown Compact Bench Scales

Specifications

Model (Single Display)	BW1.5US	BW3US	BW6US	BW15US
Model (Dual Display)	BW1.5TUS	BW3TUS	BW6TUS	BW15TUS
Certified/Approved* Capacity x Readability	1.5 kg x 0.5 g 3 lb x 0.001 lb 48 oz x 0.02 oz	3 kg x 1 g 6 lb x 0.002 lb 96 oz x 0.05 oz	6 kg x 2 g 15 lb x 0.005 lb 240 oz x 0.1 oz	15 kg x 5 g 30 lb x 0.01 lb 480 oz x 0.2 oz
Certified* Resolution	1:2,000 - 1:3,000			
Construction	ABS plastic housing with stainless steel pan			
Protection	NEMA 4 / IP65			
Pan Dimensions (W x D)	9 x 7 in / 230 x 180 mm			
Leveling Components	4 adjustable rubber feet with integral panel mounted level bubble indicator			
Display	Single or dual, red LED with adjustable brightness 6-digit, 7-segment, 0.55 in / 14 mm high characters			
Weighing Units	lb, oz, g			
Keyboard	4 raised positive feedback mechanical keys			
Span Calibration	2/3 and full scale capacity, lb/g			
Over Range Capacity	To full scale capacity +9d			
Tare Range	Full capacity by subtraction			
Zero Range	Power-on: ±10% / keyboard: ±2% full scale capacity			
Stabilization Time	Within 2 seconds			
Power	12VDC 0.84A AC Adapter / 6V 5Ah rechargeable lead acid battery			
Battery Life	50 hours continuous use with 15 hour recharge time			
Safe Overload	150% of full scale capacity			
Operating Temperature Range	10°F to 104°F / -10°C to 40°C			
Storage Temperature Range	0°F to 122°F / -25°C to 50°C			
Humidity Range	10% to 85% humidity, non-condensing			
Scale Dimensions (W x D x H)	9 x 12.2 x 5 in / 230 x 310 x 127 mm			
Shipping Dimensions (W x D x H)	11.6 x 15 x 7.5 in / 295 x 381 x 190 mm			
Scale Unit Weight	9.7 lb / 4.4 kg			
Shipping Weight	12.5 lb / 5.7 kg			

* NTEP (CC No. 08-059 for lb, kg, g units / Measurement Canada (Approval No. AM-5706 for g, lb, oz units)

Alternate Views



Rear view of dual display "T" models



Outline Dimensions

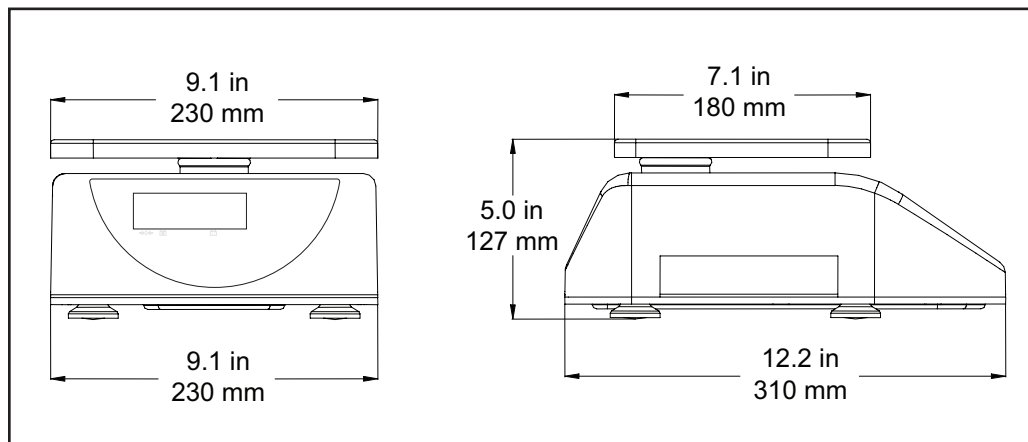

OHAUS CORPORATION

* 7 Campus Drive
Suite 310
Parsippany, NJ 07054 USA

Tel: 800.672.7722
973.377.9000
Fax: 973.944.7177

www.ohaus.com

With offices throughout Europe,
Asia, and Latin America

* ISO 9001
Registered Quality Management System

80774463_B © Copyright Ohaus Corporation

